

FEATURES:

CONFIRMATION BUTTON

Click: Play/Pause

3 sec: Activate voice assistant

8 sec: Clear Bluetooth pairing

Double click: Recall last number (Apple only)

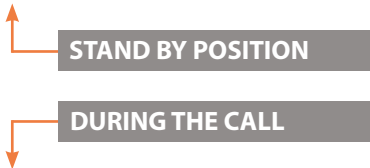

Click: Answer the call

Click during the call: End the call

Long press: Reject the call



STATUS LED

Flashing LED = Device not connected

Steady LED = Device connected

BACK BUTTON / VOLUME +

Single press: Previous track

Long press: Volume up

BACK BUTTON / VOLUME -

Single press: Next track

Long press: Volume down

ASSEMBLY:

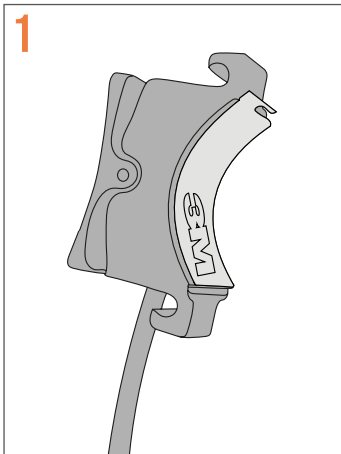

1 Remove the 3M adhesive backing protection

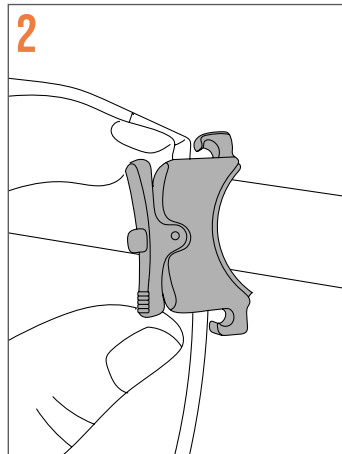

2 Apply the remote control to the handlebars or the knob

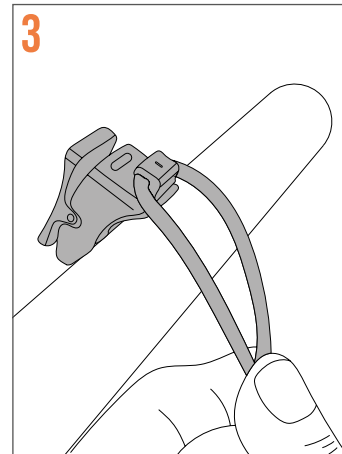

3 Secure it with the safety strap



4 Power the remote control by connecting the USB Type-A plug

SETUP:

1 • Remove the 3M adhesive backing protection

2 • The green LED will flash

3 • Open the Bluetooth settings on your phone and look for «Interphone remote control»

4 • Press and pair the device

5 • The device will be paired and the green LED will be steady

All trademarks, names, and mobile phone models are the property of their respective owners.



Distribuito da: / Distributed by:
CELLULARLINE S.p.A.
via Lambrakis 1/A
42122 Reggio Emilia - Italy
www.interphone.com
www.cellularline.com



LEGAL NOTICE

The Manufacturer is not responsible for any damage to mobile devices occurring during the use of this product. The Manufacturer will not be liable for defects resulting from damage or loss due to factors not attributable to it, nor for any tampering, damage, or defects due to improper or advised use. The Manufacturer will not be held liable for any special, indirect, consequential, or economic damage or loss suffered by the Buyer or any third party, arising from any act or omission by the Manufacturer. The Manufacturer's total liability under this warranty is limited to the replacement of the goods. The item is used at your own risk.