

OS-PLATFORMS FITTING GUIDE



Standard hoop pannier frames with 16mm up to 19mm (3/4") diameter tubes including:

- HEPCO & BECKER** Sidecarriers
- TOURATECH** pannier racks
- OUTBACK MOTORTEK** STANDARD pannier racks
- KTM** case carriers
- YAMAHA** side case stay systems (*T700 exhaust side adaptor required, see over*)
- BMW** case carriers (*GS ADVENTURE exhaust side adaptor required, see over*)
- HONDA** pannier stays

The OS-PLATFORM is designed with multiple clamp mounting holes. Five clamps are included with each OS-PLATFORM, select three mounting positions at the top and two at the base. The mounting position illustrated here is a guide. You may need to use the alternative mounting holes depending on the frame design. Mount the clamps using the five M6 x 16mm bolts supplied in the fitting kit. Add the foam inserts to the clamps for the 16mm - 18mm tube frames. We also recommend you use thread-lock on all bolts for extra safety.

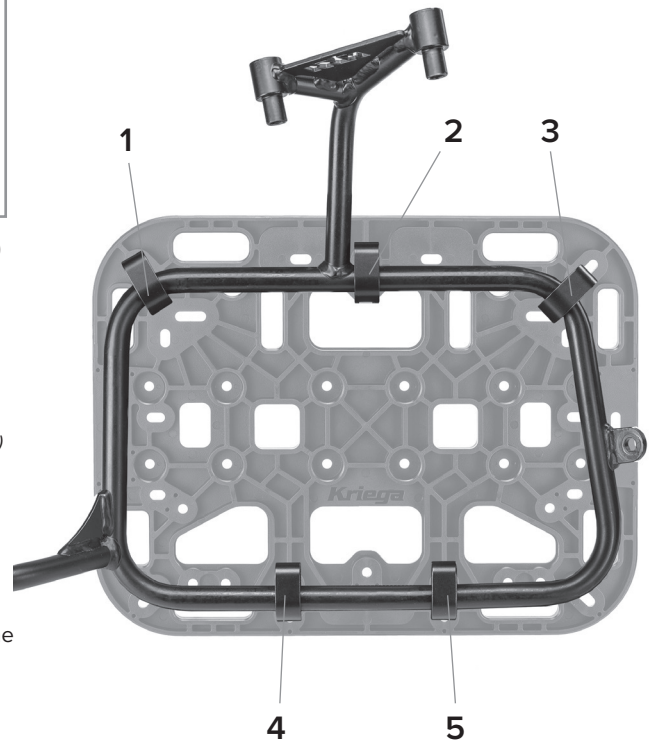

SW-MOTECH EVO & PRO Carriers

Fitting hardware is supplied with each OS-PLATFORM, attach to the EVO or PRO Carriers as illustrated below.
TIP: Fit the top centre bolt first and the rest of the holes will line up with the corresponding holes on the OS-PLATFORM.

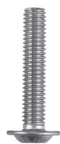
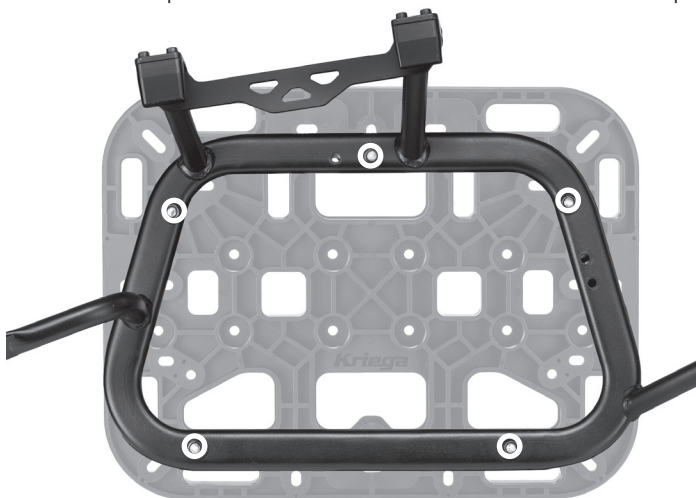

SW-Motech® EVO use the five M6 x 30mm bolts, washers and nuts per side.

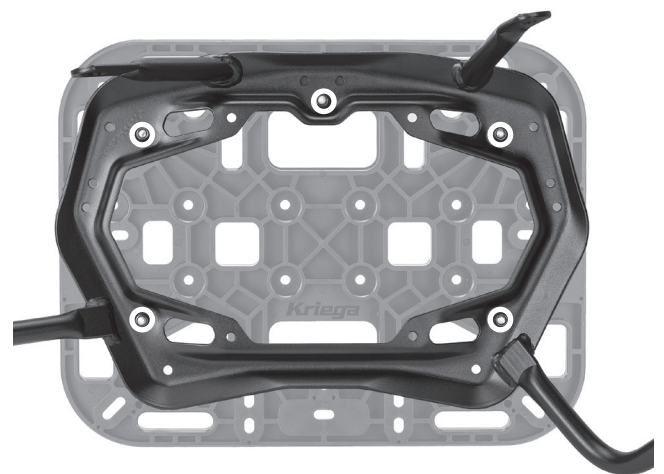

SW-Motech® PRO use the five M6 x 16mm bolts, washers and nuts per side.

GIVI Monokey Cam-Side pannier holders also supplied by HONDA, YAMAHA and TRIUMPH

To fit an OS-PLATFORM simply remove the top, front alloy section, then replace and tighten the two bolts. Also remove the two mushroom-shaped tabs at the base, if present. Mount the OS-PLATFORM in the same way as a standard tube frame, using the five clamps, three at the top and two at the base.

The rear of the OS-PLATFORM is designed with recesses to allow for the protruding bolt heads.



BMW GS ADVENTURE OEM CASE CARRIERS

Due to the extra fitting brackets the positioning of the clamps is very specific. Please follow this position guide.

The exhaust side will require additional equipment to compensate for the bend in the frame.

BMW GSA ADAPTOR BRACKET (Product code KOSPA-A)

(Sold separately)

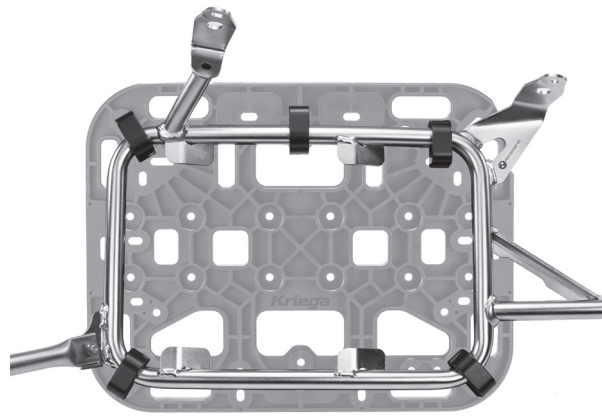

NON-EXHAUST SIDE

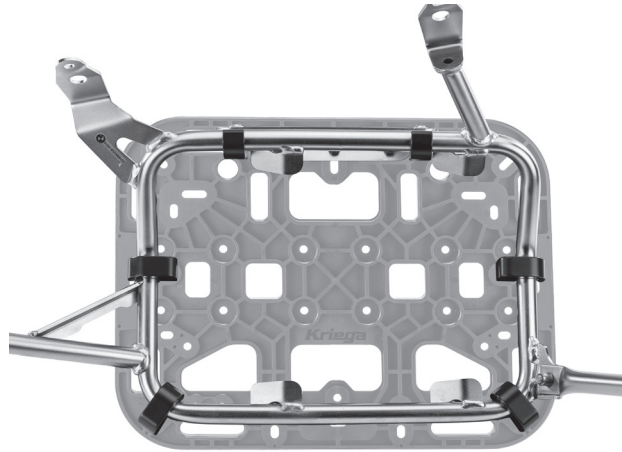

EXHAUST SIDE

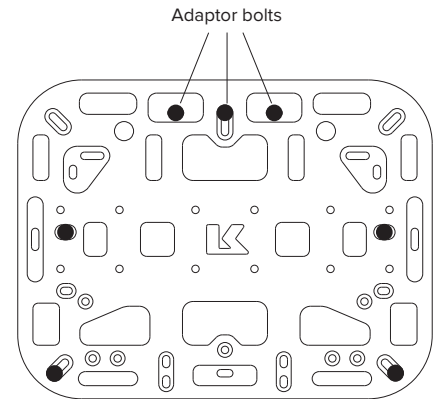
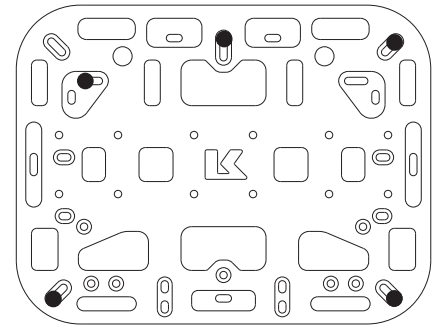

● Clamp location

YAMAHA T700 OEM CASE STAY SYSTEM

Fit five alloy clamps in the positions as illustrated. Once all clamps are in place and the OS-Platform is level with the frame you can fully tighten all the bolts. Use thread-lock on all bolts for extra safety.

The exhaust side will require additional equipment to compensate for the bend in the frame.

YAMAHA T700 ADAPTOR BRACKET (Product code KOSPA-B)

(Sold separately)

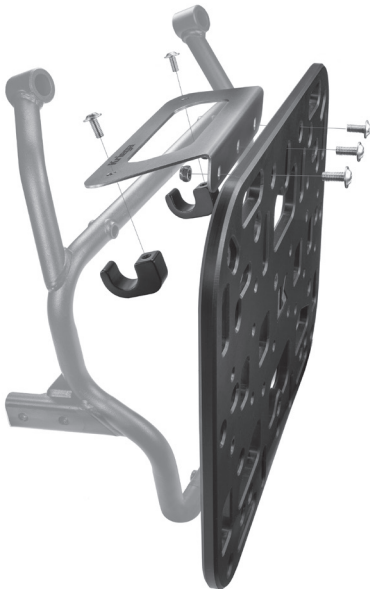

NON-EXHAUST SIDE



EXHAUST SIDE

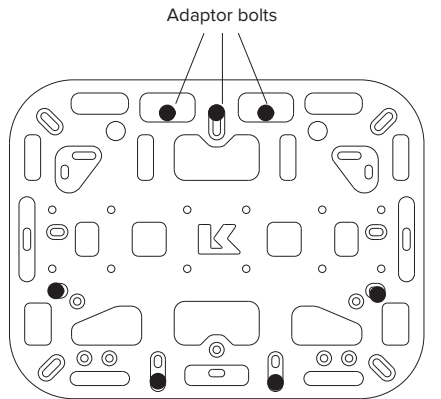
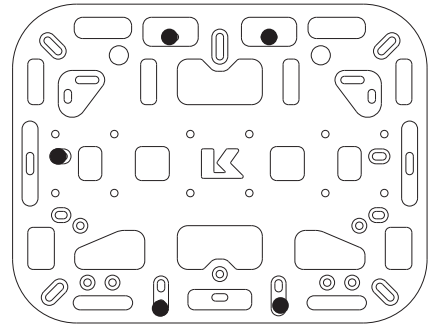

● Clamp location

It is the owner's responsibility to ensure the OS-Platforms are attached in such a way that they do not damage or put at risk the owner or the property of the owner or a third party. Do not exceed the UK legal speed limit. This product has only been tested for up to UK road legal speeds.

All information supplied here is correct at the time of going to print.